



MODULAR 4-WAY TWIN PILOT VALVES

R-433

Twin Pilot 4-Way Valve



Features:

- Indicator shows valve in shaded position
- Micro gap construction - snap action and no blow by
- Dual pilots eliminate shuttle valve
- Balanced design allows speed control at exhausts

Performance:

Flow: 9 scfm @ 100 psig; 255 l/min @ 6.9 bars
Pilot Pressure Minimum: 40 psig; 2.8 bars
Temperature: 32 to 180°F
Working Pressure: 0 to 150 psig; 0 to 10.3 bars

Description:

R-433 is a 5 ported, 4-way valve, with spring return and dual pilots.

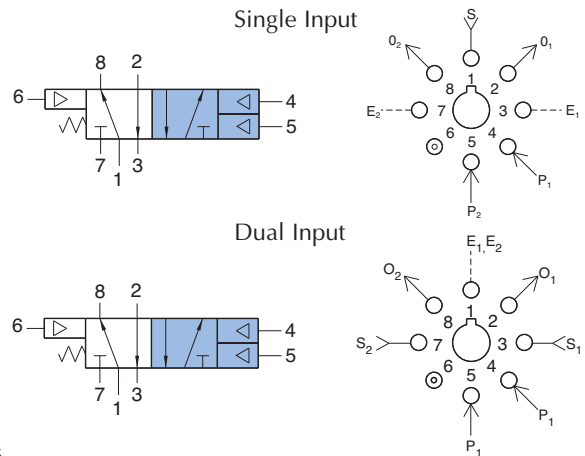

R-434

Twin Pilot 4-Way Valve



Features:

- Indicator shows valve in shaded position
- Micro gap construction - snap action and no blow by
- Dual pilots eliminate shuttle valve
- Balanced design allows speed control at exhausts

Performance:

Flow: 9 scfm @ 100 psig; 255 l/min @ 6.9 bars
Pilot Pressure Minimum: 20 psig; 1.4 bars
Temperature: 32 to 180°F
Working Pressure: 0 to 150 psig; 0 to 10.3 bars

Description:

R-434 is a 5 ported, 4-way, two position, double piloted valve.

